

# Sandwich panels assembly instruction

• **Table of contents**

<b>I.</b>	<b>Transport</b>	<b>3</b>	<b>IV.</b>	<b>Maintenance</b>	<b>19</b>
	1. Packaging	3		1. Preliminary information	22
	2. Transport	3		2. Removal of snow and dirt	22
	3. Unloading	3		3. Inspection	22
<b>II.</b>	<b>Storage and internal transport</b>	<b>6</b>		4. Sealings	22
<b>III.</b>	<b>Assembling</b>	<b>7</b>		5. Washing of the facing surface	22
	1. Weather conditions	7		6. Painting	23
	2. Health and safety considerations	7	<b>V.</b>	<b>Final remarks</b>	<b>23</b>
	3. Taking panels from package	7	<b>VI.</b>	<b>Flashings assembly guidelines</b>	<b>24</b>
	4. Assembly tools	8	<b>VII.</b>	<b>Joints between the panels</b>	<b>27</b>
	5. Preparing for the assembly	10			
	6. Protective foil	10			
	7. Cutting panels and flashings on site	11			
	8. Fasteners for panel assembly	11			
	9. Important information for designers and assembly works contractors	12			
	10. Roof panels installation	12			
	11. Wall panels installation	14			
	12. Roof sandwich panel cut-back cleaning instruction	16			
	13. Ceiling panels - special remarks	19			
	14. Energy-efficient sandwich panels ENERGY	20			
	15. Colour groups	20			
	15. Guidelines for the application of dark colour sandwich panels	20			
	17. Guidelines for the application of flat surface panels	21			

## I Transport

### 1. Packaging

Ruukki sandwich panels are delivered on load-carrying wooden pallets and non-load polystyrene pallets (package edge). Panels are wrapped in protective film. Packaging date represents the date of manufacture of the panels. Basic features of panel package:

- Package height – max 1.25 m
- Package width – max 1.17 m
- Package length – max 21.0 m
- Package weight – max 4500 kg.

### 2. Transport

- Ruukki sandwich panels can be transported only by roadworthy trucks which are covered and capable to be loaded from the top and from the side.
- Load-carrying surfaces must be clean. No nails or other sharp objects can protrude from the truck bed or its walls. Protruding objects have to be properly secured (e.g. with wooden blocks or waste foam), to avoid damage to the panels.
- The vehicle (truck bed) has to be long enough to ensure complete support coverage for the loaded package. The package is allowed to protrude no more than 1.5 m out of the truck bed.
- If the length of the truck with package exceeds 16.5 m (or the length of articulated truck with package exceeds 18.5 m), the carrier has to obtain oversized transport permit, and to provide adequate support to protect protruding panel edges from bending. Vehicles with extended truck bed have to be equipped with additional elements (e.g. sliding beams which ensure continuity of truck bed in place of pallet support). It is prohibited to use vehicles with extended truck bed to transport sandwich panels with mineral wool core.

- Packages transported by truck can be piled into max. two layers – see fig. 1 (it does not apply to panels with stainless steel facings, which cannot be piled).
- Bearing in mind the condition of highways, the carriers – drivers are bound to periodically check (after 5 km, 25 and every ~100 km) the condition of cargo fastening and to correct it accordingly.
- The recommended loading space width ranges is about 2500 mm. Minimum loading space height for covered trucks is 2600 mm.
- The vehicle carrying the panels, should be equipped with cargo straps (minimum width of 50 mm), to secure the cargo on the vehicle bed. Number of the straps depends upon the panels length; the straps should be spaced approx. every 2 m. It is recommended that the truck is provided with 2 sets of flat, 6 m long lifting slings with closed loops of load capacity 5 tons, for unloading the panels.
- Flashing packages carried together with panel packages should be fastened separately from panel packages (with separate straps).

### 3. Unloading

- Before starting to unload Ruukki sandwich panels, check the package condition.
- The packages should be unloaded with an overhead travelling crane or lift, using a cross-beam and 4-rope looped slings and approx. 6 m long flat slings with loops. Packages can be unloaded also with forklift:
- The maximum length of the package that is to be unloaded with forklift cannot exceed 6.5 m for panels with PIR core and 7.5 m for panels with mineral wool core. There is also weight limit for mineral wool panels - it cannot exceed 2 t. Packages that don't meet the above mentioned conditions are to be unloaded with travelling crane or lift. Correct handling of package is shown in fig.2–8.

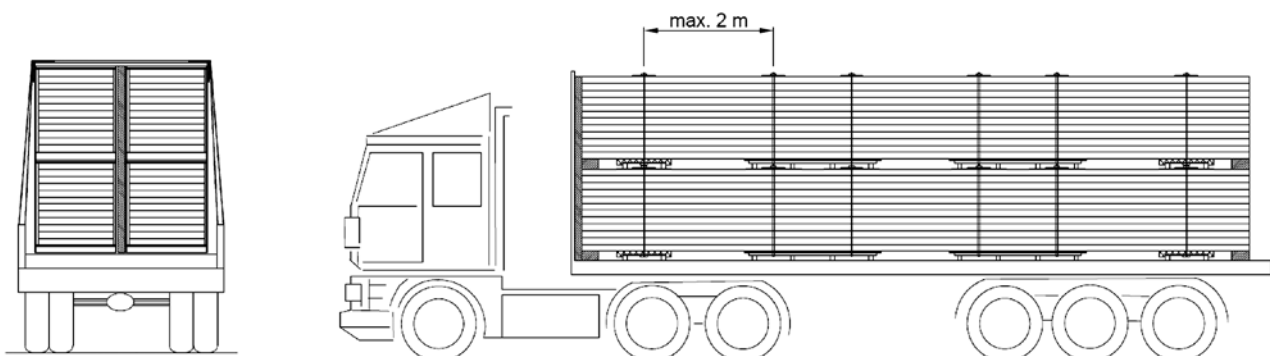

Fig. 1. A way of placing panels on transport means.

- When lifting the packages with cargo straps, attached to the load-carrying wooden pallets, use 1.2 m long and 30 mm thick wooden spacer – fig. 10, to keep the straps spacing wider than the package, to prevent the top panels from damaging. Attaching the straps to polystyrene pallets is prohibited.
- If any damage of packing/products is noticed, then it must be clearly written in CMR and Delivery Note. It is also advised to take photos showing the issue.
- **It is not allowed to install any damaged panels! Ruukki shall not be held responsible for any costs related to the installed damaged panels.**

**Unloading of panels with forklift**

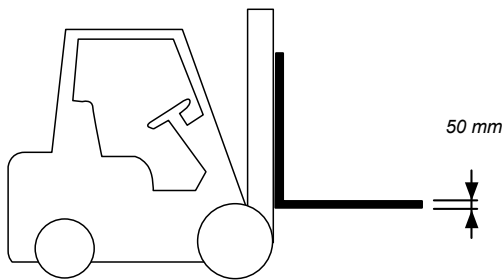

Fig.2 Ruukki packing and storage system does not allow to unload panels with forks thicker than 50 mm.

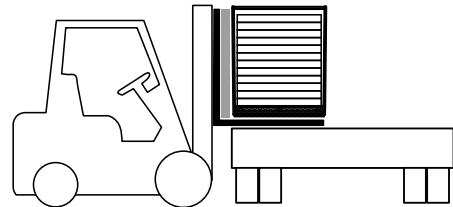

Fig.3 A forklift must be equipped with overlays from the forks' front side in order to prevent the damage of a panel lock.

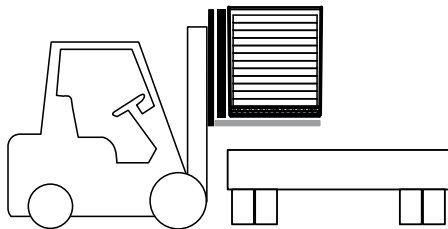

Fig.4 The length of forks must be suitable for the package width.



Fig.5 Too short forks may damage a package.



Fig.6 Too long forks may damage the second row of packages.



Fig.7 Packages should be unloaded one by one. Lifting two packages at once may damage a first panel in the first package.

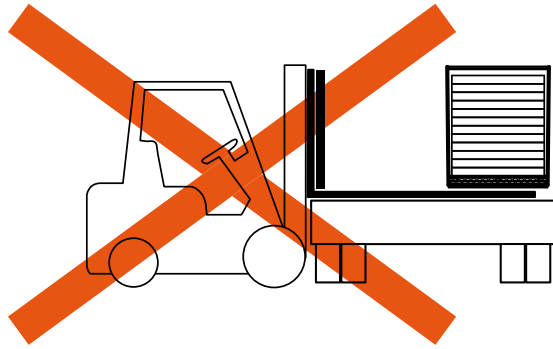
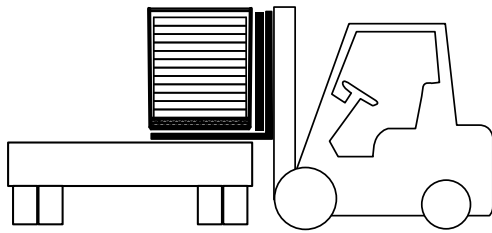

Fig. 8 Unloading must be done from two sides.

**Unloading panels with a crane/lift**

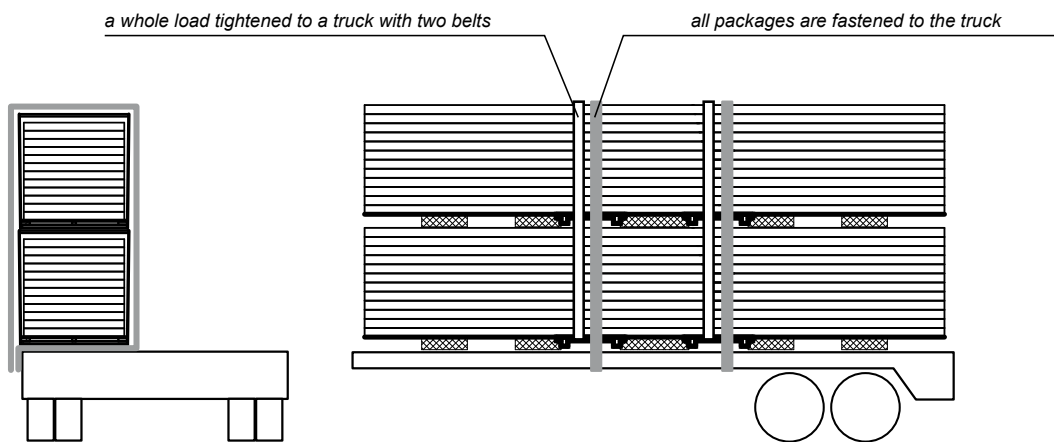

Fig. 9 If there are two places of unloading, packages must be secured additionally with cargo belts.

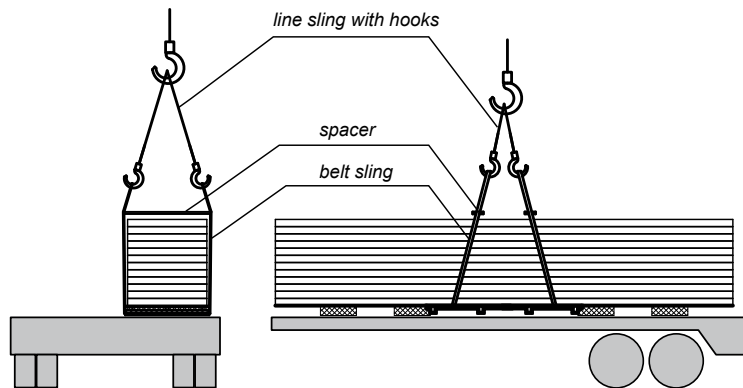

Fig. 10  
Unloading of packages up to:  
- 6,5 m long for sandwich panels with PIR core  
- 7,5 m long for sandwich panels with mineral wool core

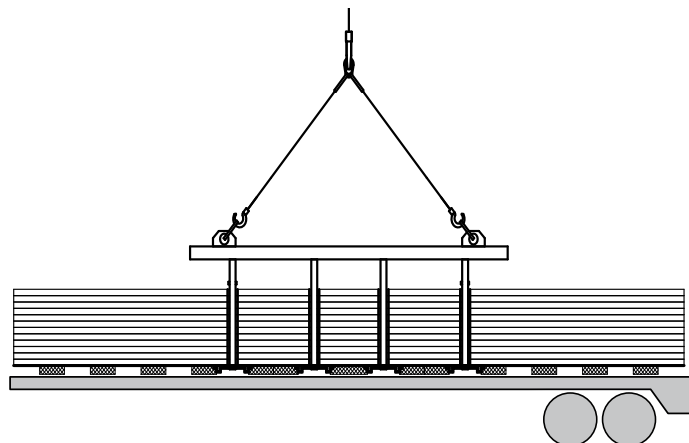

Fig. 11  
Unloading of packages longer than:  
- 6,5 m for sandwich panels with PIR core  
- 7,5 m for sandwich panels with mineral wool core

**II. Storage and internal transport**

- Store Ruukki sandwich panels in slightly inclined position, on one side edge, to ensure free drainage of rainwater which might otherwise penetrate into the package – Fig.12.
- Provide panels intended for open-air-storage with adequate protection against rainwater, snow, wind and contamination. Use canvas covers to provide adequate protection – see fig.13 (it is forbidden to use plastic film for protection purposes). The canvas covers ensure adequate ventilation and prompt evaporation of accumulated moisture. Absolutely avoid water collection between the panels, as in case of prolonged storage without adequate ventilation, this may damage them.
- **To avoid indentations and prints on the panels, it is forbidden to pile panel packages at the construction site – see fig. 14.**

- Store the packages on hardened and even surface to avoid damage to the panels. Partially unpacked panel packages must be always protected against rainwater and strong wind.
- Due to the additional load exerted on the structure, for temporary on-roof storage and during assembly, the roof panels can only be placed on the load-bearing framework. This has to be agreed each time with the chief supervisor.
- Panel packages must be supported on the load-bearing framework by their bottom pallets. For safety reasons, the packages may not be piled while stored on the roof structure.
- It is not allowed to transport piled packages

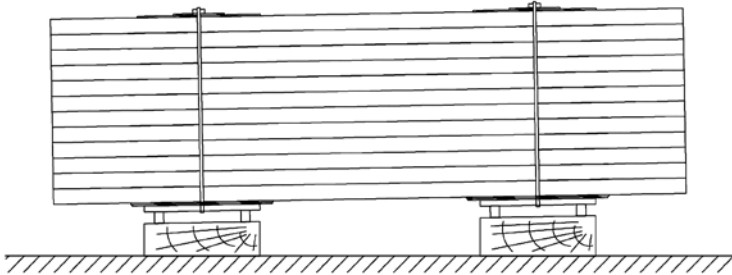

Fig. 12. Panels storage with difference of levels along side edge.

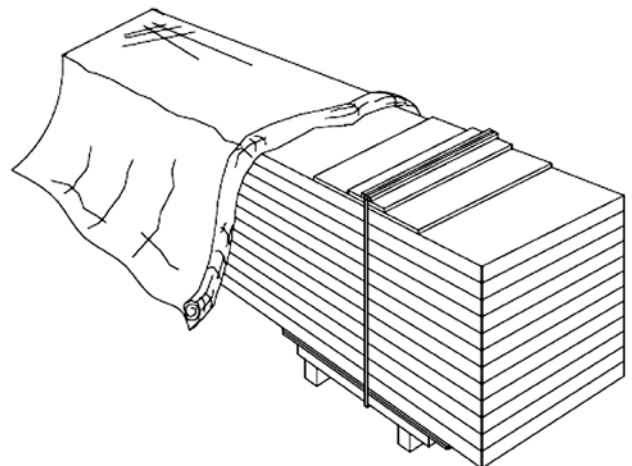

Fig. 13. Correct protection of panels with textile cover.

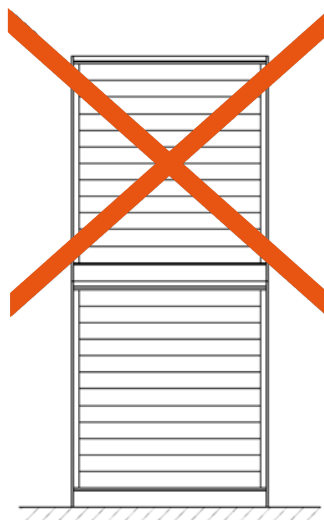

Fig. 14. It is not allowed to pile panels at the building site.

### III. Assembling

#### 1. Weather conditions

The following weather conditions are of critical importance for assembly of Ruukki sandwich panels: wind speed, precipitation, visibility. Due to the relatively low weight-surface ratio of the panels, the wind speed should not exceed 4 degrees Beaufort (9 m/s). The panels should not be installed during snow and rain falls or during a dense fog. The panel assembly works should be stopped when the visibility reduces at dusk, and there is no artificial lighting provided.

It is recommended to install panels within the temperature range from -5°C . If there is no EPDM seal in the lock (factory-applied), sealing process requires temperature over 4°C.

Information about assembly temperature for the panels of third color group is given in p. III.14.

#### 2. Health and safety considerations

All works related to the assembly of Ruukki sandwich panels, have to be carried out in accordance with the applicable occupational health and safety regulations for the assembly and roofing works, under supervision of authorized staff. In addition use the following fall restraint equipment during panel assembly:

- Rope barriers to secure the building's in perimeter.
- Lifelines and safety belts of assembler type .
- Safety apparatus.

#### 3. Taking panels from package

- The use of a lift is the most convenient method for panel assembly on the roof.
- While assembling the panels with the use of a lift, bear in mind the roof inclination, otherwise the panel edges might get damaged.
- Panels with a low specific weight can be manually lifted and placed on roof.
- Remove the protection film from the inside panel facing before placing it onto the roof structure.
- Soft shoes (in order not to damage panel coating) should be worn by the workers while installing the roof panels.
- Merge each subsequent panel with the previous one by putting the trapezoid-shaped flash of the top panel cladding onto the ridge of the adjoining panel.
- The lengthwise displacement should be reduced to minimum, to protect the sealants.

**4. Assembly tools**

**Vacuum lifting devices**

VIAVAC vacuum lifters are used for safe and easy lifting of the panels. The selection of particular VIAVAC device depends on the type and length of panels as well as the specifics of particular assembly. When carrying the panels, it is necessary to follow the instructions provided by technical department of company engaged in the rental of VIAVAC devices in order not to damage the panel. Renting of VIAVAC lifting devices is a proper solution for assembling crew in order to secure safety rules.

**As to ensure safety whilst lifting with VIAVAC vacuum lifters, the foil applied onto the panel surface must be removed.**



Pic. 1 and 2. VIAVAC vacuum lifter

**Self-clamping tools**

Special self-clamping tools help to ensure proper piece joining without the risk of any damage to panel edges. They are used for horizontal arrangement.

For lifting panels in horizontal panel arrangement two assembly tools should be used at least. You can find detailed information in our guides named „Instruction for applying lifting assembly tool” and „The rules for borrowing lifting assembly tools from Ruukki”.

Notice: there are different clamping tools dedicated for particular panels.

For new Ruukki nSPB panels with mineral wool core only lifting tools marked PTH2022 can be used.

For new Ruukki nSPD panels with mineral wool core only lifting tools marked PTH2023 can be used

For Ruukki SPB and SP2D panels with mineral wool core only lifting tools marked PTH2006 can be used.

For Ruukki SP2B, SP2E and SP2D panels with PIR core only lifting tools marked PSP 2011 can be used



Pic. 3. Self-clamping tools: from left: PTH 2006, PSP 2011, PTH2022.

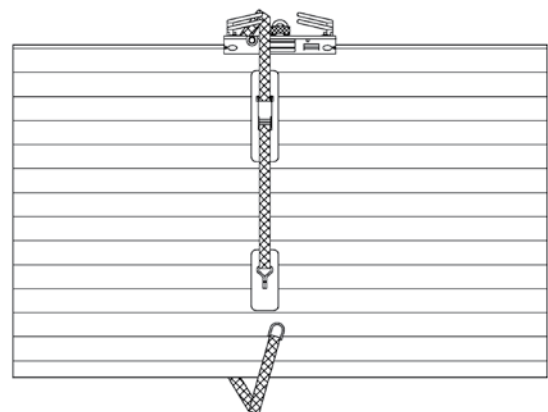

Fig.15. Self-clamping tools.

**Screw drivers**

- Install self-drilling fasteners in general 1,200-2,000 rpm
- Recommended drilling pressure for self-drilling fasteners 200-300 N
- Use clean tool, which fits exactly for installation of painted fasteners

**Sawing machines, shears**

- It is recommended to cut Ruukki sandwich panels with sawing machines having fine-toothed blades, or with circular saws, provided that they are fitted with accurate guiding systems. Remove swarf immediately after cutting – see pic. 4 and 5.

No angle grinders, and any other machines that might cause overheating within the cutting zone – and consequently damage the corrosion protection – are allowed for cutting panels and flashings – see pic. 6 and 7.

- Use snips for cutting flashings.



Pic. 4 and 5. Sawing machines are recommended for panel cutting.

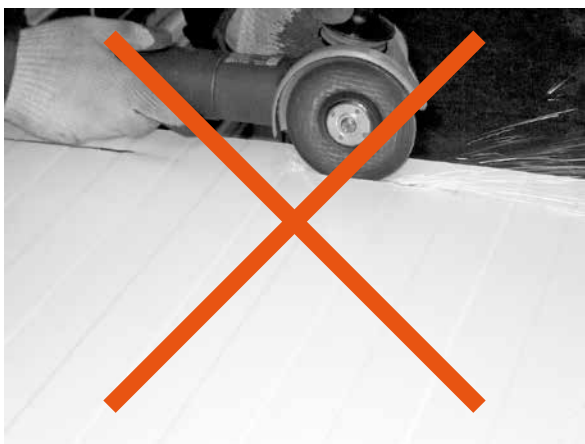
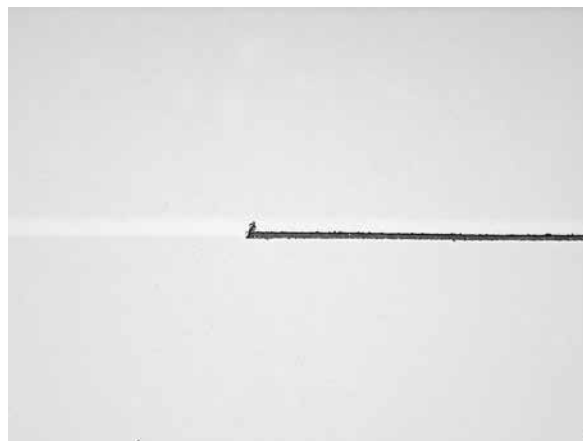

Pic. 6 and 7. Do not cut panels with angular grinding machine as anticorrosive covers can be devastated.

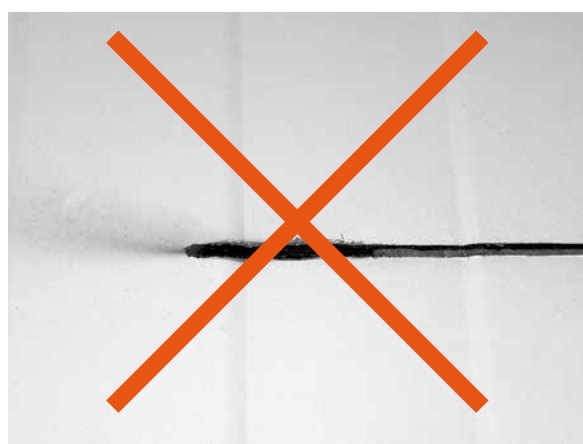

**5. Preparing for the assembly**

Before you attempt to install Ruukki sandwich panels proceed as follows:

- Check the structure for compliance with design specifications and construction accuracy (rectify any possible discrepancies).
- Make sure the spacing of purlins, columns and spandrel beams is consistent with the guidelines contained in static load tables.
- Make sure the purlins surfaces form a plane.
- Verify the alignment of columns and spandrels of the wall structure. Any errors or discrepancies should be reported to site manager and Ruukki sales department representative.
- Check the quality of plinth related works and other wet works performance.
- Prepare necessary tools for assembly of panels.

Proper structure preparation will facilitate the assembly, and result in faultless performance of fasteners and joints, ensuring aesthetical building finish. No welding is allowed in the proximity of panels as this might permanently damage the panel coat.

**6. Protective foil**

- The facings of panels manufactured by Ruukki are protected with a protective film against dirt and damage. Even after short-term exposure to weather conditions, the film starts to crack and problems with film removal might occur.
- The Buyer is obliged to remove the protective film not later than three (3) months from the delivery date given in Sales Order Confirmation. It is required in order to avoid the consequences of film vulcanization, which happens to the film as a result of exposure to weather conditions. The consequences of vulcanization are: colour change of protective film, difficulties with film removal, tearing of the film during its removal, presence of glue residue or even damages to the coating of panel facing.
- Regardless of the provisions mentioned in the point above, protective film must be removed before installation or just after panel installation is completed. If panels are installed by using vacuum lifters (VIAVAC), the protective film must be removed before lifting tool is attached to the panel surface. It is required to use VIAVAC tools according to the manual. In case of revealing any quality issue after foil removal, it is required to stop the installation process and inform Ruukki representative immediately about the problem. Otherwise Ruukki shall not be responsible for panel replacement costs.
- Peel the protective film off the longitudinal edges of Ruukki nSPD with mineral wool core prior to installation start.

- Remove protective film from internal cladding of panels, where such elements as flanges, dome skylights or water drains are installed – see fig. 16.
- Internal facing of nSPB or SP2B panels is covered with blue protective film, if panel facings have the same colour and profiling.
- If the elevation/external side of Ruukki SP2B, SP2E, nSPB panels is made of same colours and same profiling as internal one, then the external side is marked on the panel side with the following overprint: elewac-ja ↓ outside ↓. Arrows indicate external facing of panel.
- Assembly inconsistent with marking will cause loss of warranty.

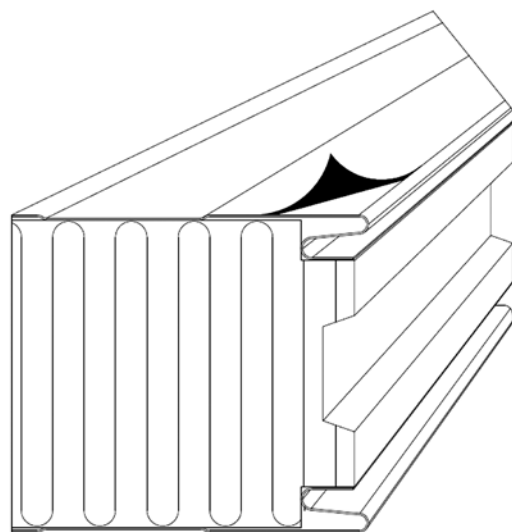

Fig. 16. Peel off protective film from internal facing of panels.

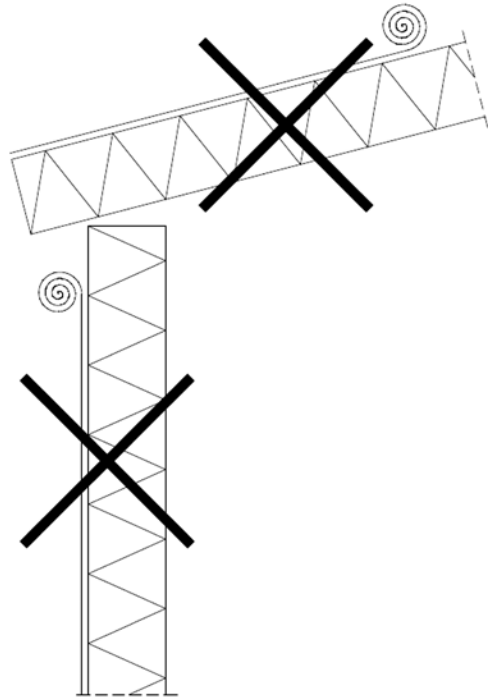

Fig. 17. It is not allowed to leave a film as shown.

**7. Cutting panels and flashings on site**

- Openings cut in roof and wall components, before the panel is assembled, weaken its cross-sectional structure, therefore adequate stiffening should be provided in those places.
- The method of cutting flashings is shown on pages 20 – 22.
- In order to protect the surface from damage cut the panels and flashings on special stands lined with soft fabric such as felt etc.
- Secure edges of panels and flashings immediately after they are cut. Remove the protective film, if any, from the flashings, before their assembly.
- It is prohibited to cut the panels on roof, work platforms, scaffolding etc.

**8. Fasteners for panel assembly**

Use manufacturer recommended self-drilling fasteners for fixing Ruukki sandwich panels. The fastener type depends upon the load carrying structure and the thickness of panel being assembled. In order to achieve adequate fastening of the panel to the structure, it is essential to maintain perpendicular fastener position while fixing, therefore the use of special screw guns fitted with heads for long fasteners is highly recommended.

Use stainless steel fasteners for fixing panels to structures where the following conditions are present:

- The atmosphere inside is characterised by a permanent moisture content of above 70%.
- Chemically aggressive atmosphere is present inside.
- The equipment stored requires particular protection.

Thanks to specially designed support thread with no thread in the area under fastener head and a stainless washer with EPDM vulcanised layer, watertight and durable fastening is achieved in one operation, which eliminates clearance between the sandwich panel and its base (spandrel beam, purlin or other steel structure component) – see fig. 18

When other than steel fasteners were chosen, please contact Ruukki sales representative.

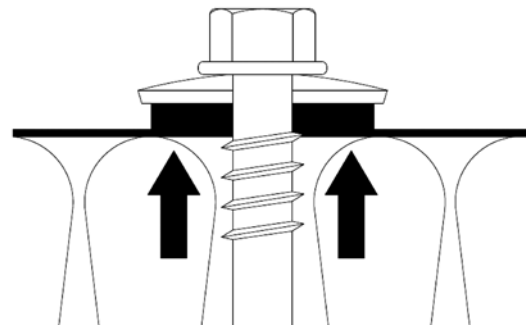

Fig. 18. Correct installation of fastener.

**9. Important information for designers and assembly works contractors**

- Proper layout of particular elements of construction work (edges, continuous colour elements in different colours, continuous belts of window frames, etc.) yet made in the stage of architectural planning can visually lighten the building and hide minor colour deviations.
- Assembly work contractor should, if possible, assemble panels according to sequence of panels numeration (it mainly refers to panels in metallic colours, e.g. RAL 9006, RAL 9007).
- Assembly of panels and flashings should always proceed in accordance with production course. Rotation by 180° automatically leads to colour differences in a place of joining a particular element with element already reversed. Colour differences will occur again in a place of joining with a panel assembled in accordance with production course.
- Assembly in large spaces requires current assessment of achieved colour conformity from the distance of at least 25 m and from different angles. The further an assessing person stands from an assessed construction work, the more visible are even relatively minor colour differences. During assembly of panels with facings in metallic colours assessment should be made as often as possible and from many sides (places). Moreover, in order to facilitate assessment properly, the protective film must be removed. Panels should not be assessed whilst direct high sun exposure.
- In case of assembling panels from different production lots (on one object/ one facade), after installing of a panel coming from a different lot than previous one, it is recommended to peel protective film in order to check whether there are colour differences. If so, then stop assembling panels and contact Ruukki sales representative. Otherwise Ruukki shall not be held responsible for any colour differences found during and after installation of sandwich panels.
- Different products within same Sales Order and same RAL might have slight colour differences. In case of different products or same products but in different metal sheet thicknesses, the customer should agree in writing with a sale representative which part of the order/contract must be produced within same colour shade. Otherwise Ruukki shall not be responsible for any colour differences.
- Manufacturers of color coated facings do not guarantee consistency of colour tones/shades of next deliveries due to the complexity of technological processes. It applies especially to metal sheets in metallic colours RAL9006 and RAL9007. In order to avoid problems with colour differences, the customer should agree in writing with a sale representative which part of the order/contract concerns the delivery for one ob-

ject. In case of such an agreement Ruukki is obliged to deliver panels made of the same batch of input material. Otherwise Ruukki shall not be responsible for any colour differences.

**10. Roof panel installation**

- At first, fix the panel with one fastener to the purlin below the roof ridge, then at the eaves and to the other purlins (except for the roof ridge purlin).
- The edge panels are fixed to the structure (purlin) with three self-drilling fasteners through the top of the trapezoidal panel.
- The middle panels are fixed to the structure (purlin) with two fasteners.
- The same self-drilling fasteners are used for fixing both, the middle and edge panels, i.e. fastener for hot rolled and fastener for cold-bent purlins (information about fasteners can be found in catalogue “Accessories for sandwich panels”).
- In order to ensure complete joint tightness use additional L03 self-drilling fastener spaced approximately every ~ 300 mm or acc. to engineering design of the structure.
- The use of a multipurpose screw driver is recommended for fixing L03 fasteners (with adjustable downforce). Due to diversified loads in nominal and edge zones, the final number of fasteners is defined by constructor in the project.
- Sandwich panels are unsuitable for cyclic/repeated loads (like repeated walking).
- If regular/repeated access to the roof is required, use appropriately designed platforms, which are supported on the frame and which do not load the panel structures (walking must take place on the platforms so that the sandwich panels are not subjected to the impact from walking).
- Any loads that may act on the sandwich panel should be taken into account when dimensioning.
- It is not allowed to store any goods/materials on sandwich panels.



Pic. 8 and 9. Assembly of roof panels.

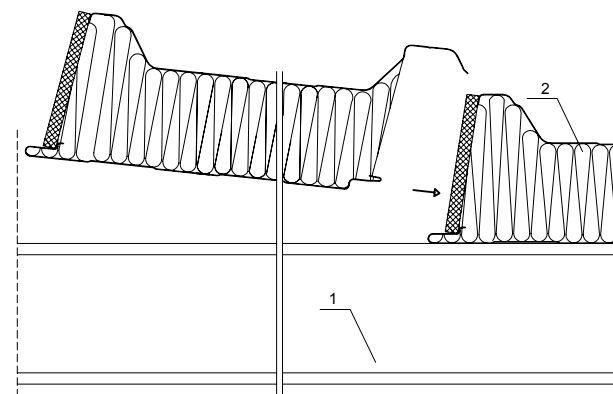

A.

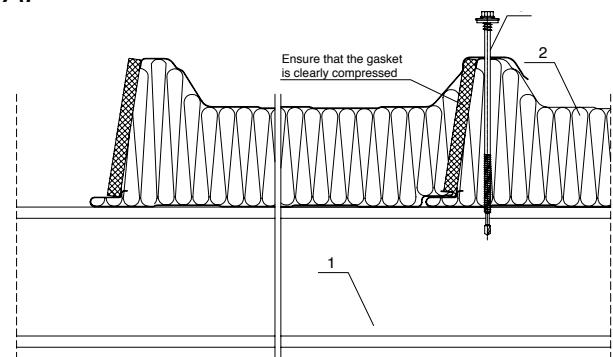

B.

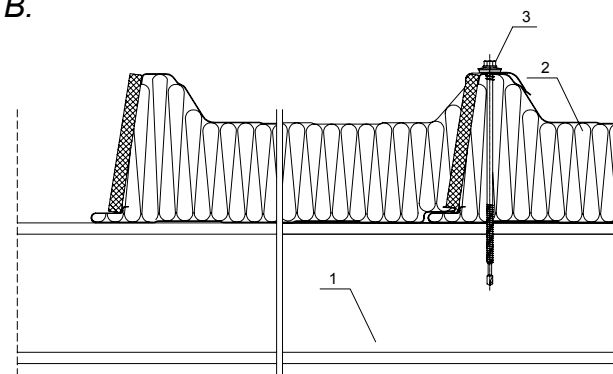

C.

Fig. 19. Sample assembly of sandwich panels, where:

- 1 – beam
- 2 – sandwich panel SP2C PIR
- 3 – fastener

Remark: The seal is 30% compressed when panels are installed properly.

The following minimum inclination of roof made of Ruukki sandwich panels is required:

- >5% for roofs of continuous panels without transverse joining and skylights
- >7% for roofs of joined panels without skylights
- >10% for roofs of joined panels with skylights

Minimum width for roof supports - always check the support for compliance with design specifications – see fig. 20 and 21. When adjusting width of supports, it is necessary to consider remarks included in TrayPan software.

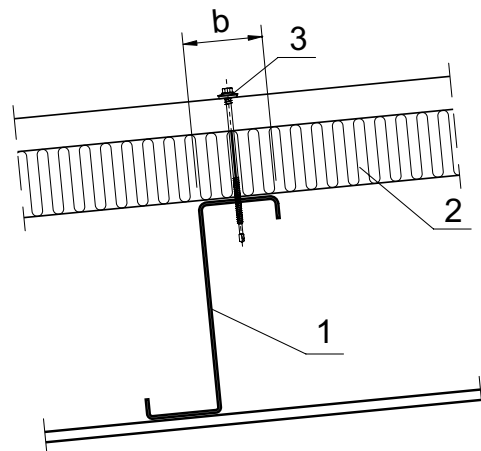

Fig. 20. Intermediate supports  $b \geq 60$  mm, where:

- 1 – steel purlin
- 2 – roof panel
- 3 – fastener

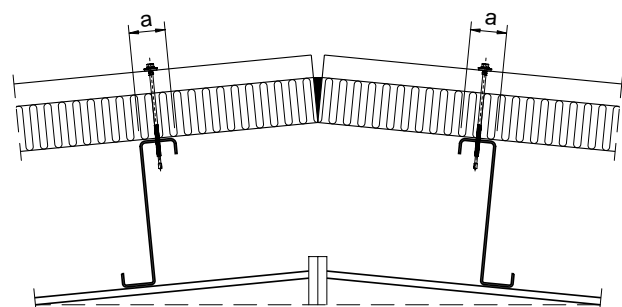

Fig. 21. Extreme supports  $a \geq 40$  mm.

### Roof ridge

After assembling Ruukki roof panels proceed as follows:

- Rivet bottom ridge flashing, between the roof ridge purlins.
- Fill the gap between the panels with polyurethane foam; after the foam has cured cut possible flash off and place U01 shaped polyethylene sealant on both sides of the roof ridge. In case of panels thicker than 120 mm half of the gap should be filled with soft mineral wool and a second half with expanding foam.
- In case of mineral wool core roof panels fill the gap between panels at the core depth with butyl sealing compound and mineral wool.
- Fix side ridge flashing to panel ridges with L03 fasteners or with tight rivets.
- Apply the self-adhesive polyurethane sealant to side ridge flashing.
- Put top ridge flashing on the roof ridge top and fix it with roofing sandwich panel using L03 fasteners.

### Eaves

When constructing eaves of Ruukki roof panels proceed as follows:

#### Option 1: PVC gutter:

- In order to provide adequate dewatering of the roof surface, finish the eaves panels with drip roof flashing.
- Cut the core under the top panel facing, using an electric drill of minimum 3000 rpm with an extended min. 65 mm long and around 5 mm diameter twist drill (make the cut crosswise the panel, under its top facing).
- Fit assembly flashing in and fix it to the bottom panel cladding.
- Fasten gutter hooks to assembly flashing, in order to ensure appropriate gutter inclination.
- Fit drip roof flashing under the top panel facing and rivet it down with tight rivets and apply sealing compound along the strip.
- Place PVC gutters.
- Place drip roof flashing onto the eaves ridges.

#### Option II - steel gutter:

- In order to provide adequate dewatering of the roof surface, finish the eaves panels with drip roof flashings.
- Cut the core under the top panel facing, using an electric drill of minimum 3 000 rpm with an extended min. 65 mm long and around 5 mm diameter twist drill (make the cut crosswise the panel, under its top facing).
- Fit in drip roof flashing and rivet it.
- Apply drip roof flashing to the bottom panel facing and rivet it to the panel.
- Fasten gutter hooks to the panel, so arranged to ensure appropriate gutter inclination.
- Fit the steel gutter and apply sealant along drip roof flashing.
- Place drip roof flashing onto the eaves ridges.

### 11. Wall panel installation

- The use of a lift is the most convenient method for assembly of Ruukki wall panels.
- Prepare lifting sling of appropriate length, matched to that of the panel.
- Panels can also be lifted from the package using vacuum lifting devices or other special lifting assembly tools for sandwich panels.
- Slide the top package panel off as far as two holes can be drilled, to allow placing bolts through the holder and through the panel, or to allow applying tools for lifting of the panel.
- Panels with low specific weight can be lifted from the pack and placed manually.
- Remove the protective film from the internal facing of the panel before assembly, and put impregnated polyurethane sealant on the ground beam.
- Put plinth flashing (width depending on the panel thickness) on the sealant.
- Position the panel vertically after placing it against the structure. Level the drip and fix the panel complete with the drip (applies to vertical panel arrangement) to the plinth rail. Precise positioning of the edge panel will help to avoid misalignment of all panels in a row.
- The tongue-and-groove system makes the assembly of panels much faster.
- In order to ensure desired tightness of the longitudinal joint, press the components together without damaging panel edges.
- It is important to ensure that after installation of two panels, the side polyurethane gasket is clearly compressed.

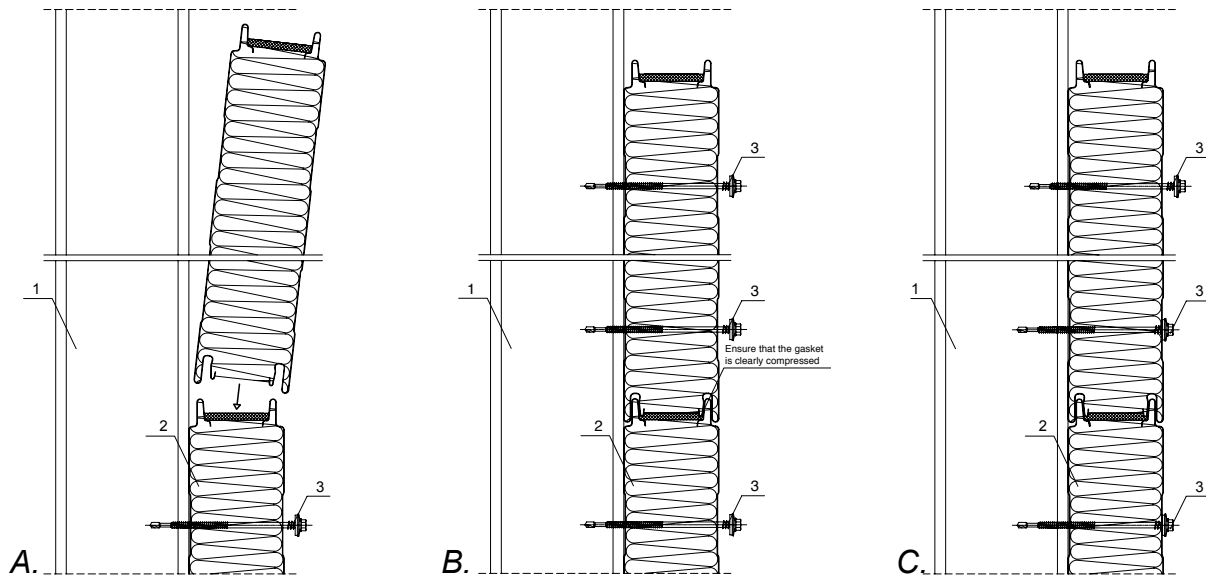

Fig. 22. Sample assembly of sandwich panels in horizontal arrangement, where:

- 1 – column
- 2 – sandwich panel SP2B PIR
- 3 – fastener

Remark: The seal is 30% compressed when panels are installed properly.

- If panel is equipped with EPDM sealants, then the sealants must be in proper contact with opposite part of the other panel and clearly compressed when panes are installed on final position.
- If there is no originally pre-installed EPDM in the panels' steel grooves, either butyl sealing compound or EPDM seals are to be applied on site before installation.
- Regardless of the core type, it is important to maintain alignment of horizontal and vertical joints – see fig. 23.
- Proper control of modular width is always required, with special attention to the situations when different panel types are installed in adjacent sections of the wall.

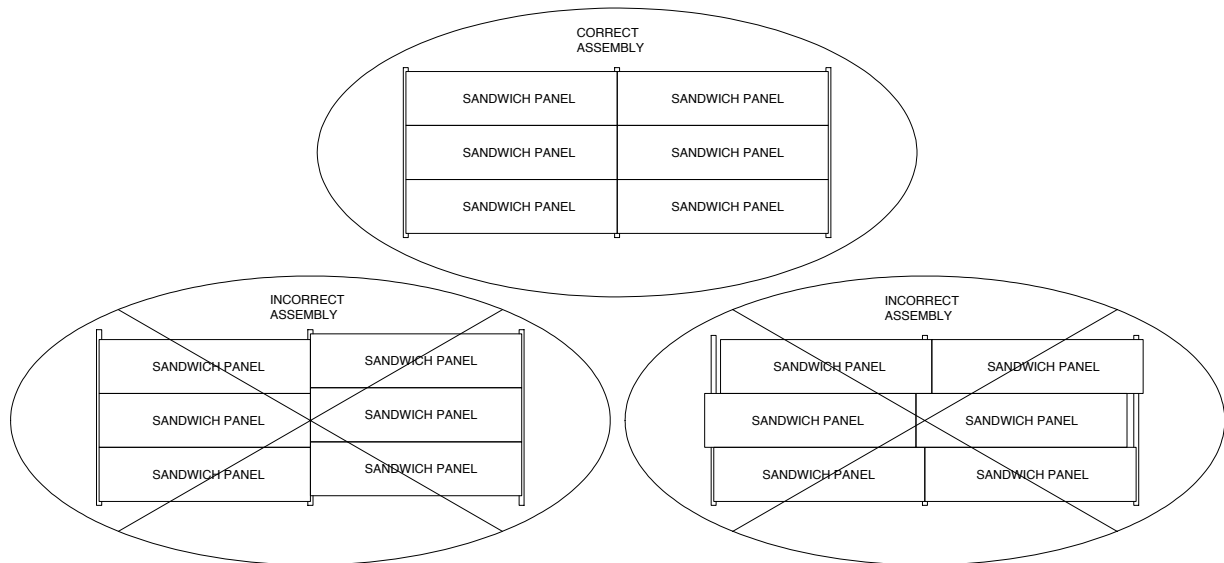

Fig. 23. Alignment of horizontal and vertical joints

**12. Roof sandwich panel cut-back cleaning instruction**

Roof sandwich panels with left and right cut-back options require mechanical processing on-site before panel installation. The mechanical processing involves the removal of the factory-cut internal metal facing and the panel core. This process aims to eliminate excess material and prepare the panel for installation, preventing potential damage and ensuring a clean and aesthetic finish.

**Available cut-back variants for roof panels with PIR core:**

- **Cut-back PIR**

In this variant the manufacturer performs a cut of the internal metal facing and a partial incision of the core. Excess material is removed during installation by following steps described below.

- **Cut-back PIR with foil**

- In this variant the manufacturer performs a cut of the internal metal facing, a partial incision of the core and applies foil on the trapezoidal metal facing from the core side. Excess material is removed during installation after completing the steps described below. This solution allows quick and easy removal of the PIR core in the cut-back area.

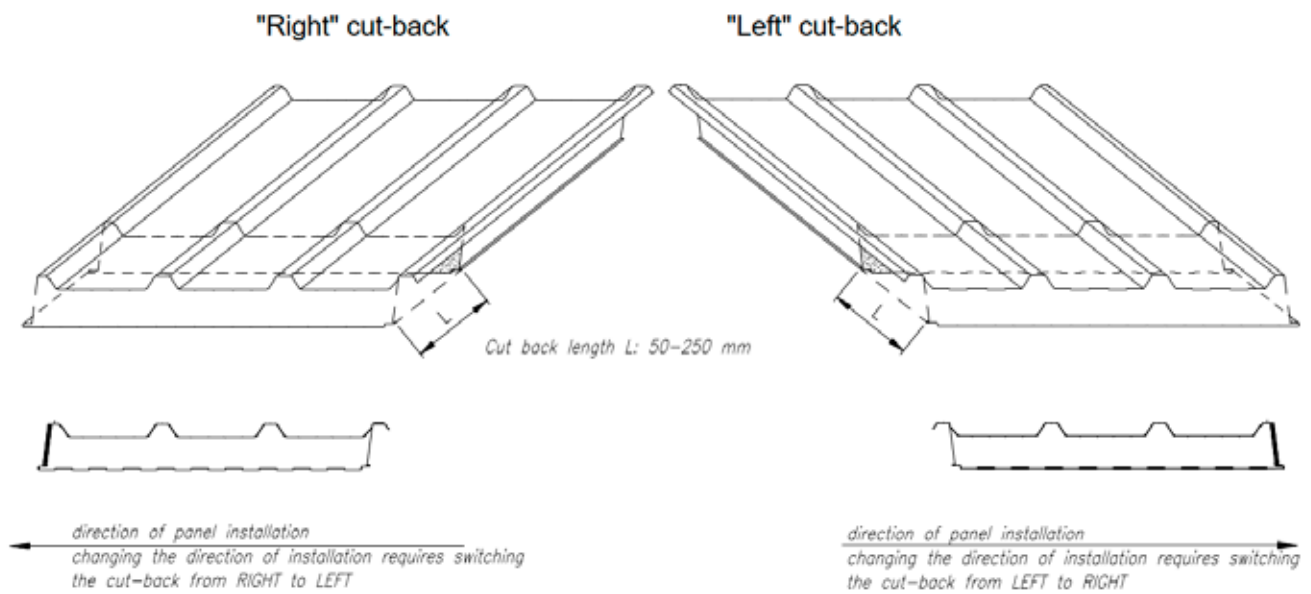













Fig. 24 Factory prepared cut-back scheme for SP2C PIR or nSPC W sandwich panels

**Roof sandwich panel cut-back cleaning process before installation:**

<p><b>Roof sandwich panel with PIR core – SP2C Cut-back PIR</b></p>	<p><b>Roof sandwich panel with PIR – SP2C Cut-back PIR with foil</b></p>	<p><b>Roof sandwich panel with MW core – nSPC</b></p>
<p><b>Step 1. Removal of the cut internal facing:</b></p> <ul style="list-style-type: none"> <li>- remove the metal sheet from the cut-back section of the panel.</li> </ul> 	<p><b>Step 1. Removal of the cut internal facing:</b></p> <ul style="list-style-type: none"> <li>- remove the metal sheet from the cut-back section of the panel.</li> </ul> 	<p><b>Step 1. Removal of the cut internal facing:</b></p> <ul style="list-style-type: none"> <li>- remove the metal sheet from the cut-back section of the panel.</li> </ul> 
<p><b>Step 2. Trimming the panel core:</b></p> <ul style="list-style-type: none"> <li>- use a knife to trim the remaining part of the core along with the sealing strip up to the external facing, be careful not to damage it.</li> </ul>   <p>Trimming the panel core is essential—failure to do so correctly may result in damage of the core beyond the cut-back area</p>	<p><b>Step 2. Trimming the panel core:</b></p> <ul style="list-style-type: none"> <li>- use a knife to trim the remaining part of the core along with the sealing strip up to the external facing, be careful not to damage it.</li> </ul>   <p>Trimming the panel core is essential—failure to do so correctly may result in damage of the core beyond the cut-back area</p>	<p><b>Step 2. Trimming the panel core:</b></p> <ul style="list-style-type: none"> <li>- use a knife to trim the remaining part of the core along up to the external facing, be careful not to damage it.</li> </ul>  <p>Trimming the panel core is essential—failure to do so correctly may result in damage of the core beyond the cut-back area</p>
<p><b>Step 3. Removal of the panel core:</b></p> <ul style="list-style-type: none"> <li>- manually remove the foam from the metal facing using a sharp tool.</li> </ul> 	<p><b>Step 3. Removal of the panel core:</b></p> <ul style="list-style-type: none"> <li>- lift the foam at the joint between the foam and the profiled metal facing using a knife to detach the foam from the metal sheet.</li> </ul> 	<p><b>Step 3. Removal of the panel core:</b></p> <ul style="list-style-type: none"> <li>- manually remove the foam from the metal facing using a sharp tool.</li> </ul> 

**Step 4. Preparation of the external metal facing:**

- carefully clean the metal facing.



Any damage of the coating must be repaired with paint before panel installation.

**Step 4. Preparation of the external metal facing:**

- remove the foil and any foam residue from the metal surface.



Any damage of the coating must be repaired with paint before panel installation.

**Step 4. Surface leveling of the core:**

- level the wool core from the incision line to the coating layer.



Any damage of the coating must be repaired with paint before panel installation.

**Step 5. Properly prepared panel ready for installation:**



**Step 5. Properly prepared panel ready for installation:**



**Step 5. Properly prepared panel ready for installation:**



**13. Ceiling panels - special remarks:**

- Sandwich panels are unsuitable for repeated loads (like repeated walking).
- When the sandwich panels are used as a ceiling extreme care must be taken not to walk on the panels.
- During the installation if an access is absolutely required only temporary access for one person (human + equipment/tools = max. 120 kg) is allowed and only when panel surface has been properly protected in advance. **Walking on unprotected panel surfaces is forbidden.**
- An example of panel surface protection is presented below and on the graphics on the side.
- Flexible fibreboards with a minimum width of 600 mm are placed in the area where walking is required (max. 120 kg = one person + equipment/tools). On top of the fibreboard, a rigid plywood board is placed, which is at least 10 mm thick and substantially narrower and shorter than the fibreboard. Walking is allowed on the plywood board, which has been placed on the top of the fibreboard. The layers made of the boards should be placed with overlaps. It is required that the lower layer be soft and the upper layer rigid (hard).
- After installation if any access to the ceiling is required, use appropriately designed platforms, which are supported on the frame and which do not load the panel structures (walking must take place on the platforms so that the sandwich panels are not subjected to the impact from walking).
- Any loads that may act on the sandwich panel should be taken into account when dimensioning.
- It is not allowed to store any goods/materials on sandwich panels.

• **Panel surface protection:**

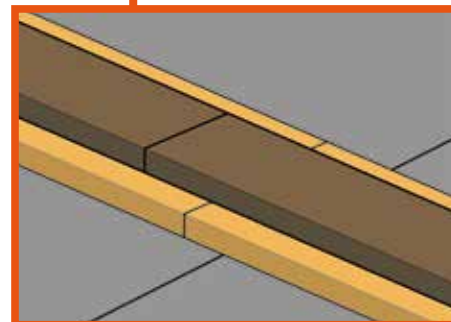
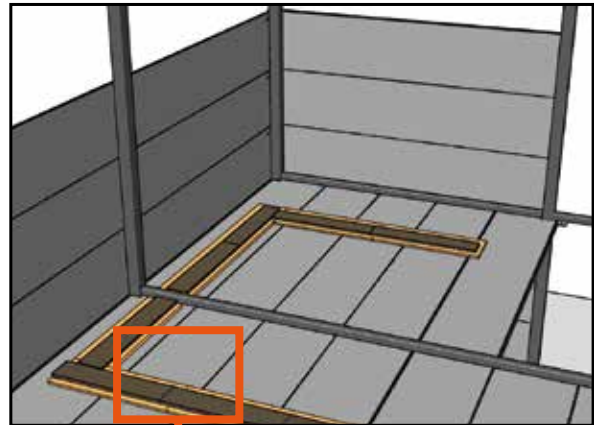

**14. Energy-efficient sandwich panels RUUKKI ENERGY**

The main advantage of RUUKKI ENERGY panels is improved air tightness and thermal performance compared to standard sandwich panels. Better air tightness class is achieved by special ENERGY seals and by maintaining minimum technical tolerances in the production process. Thanks to the proper design, ENERGY panels can provide air-tightness of the envelope at the level which meets the standards for passive buildings.

It is important to ensure that the sealants are in proper contact with opposite part of another panel and clearly compressed when panels are installed on final position.

Examples of RUUKKI ENERGY system detailing are available at [ruukki.com](http://ruukki.com).

**15. Colour groups**

The division of panels into colour groups shown in the table is connected with the influence of thermal load on cladding made of sandwich panels. When exposed to solar radiation steel facing in dark colours absorbs more heat.

Due to a considerable difference between the temperature ( $\Delta t$ ) of external and internal facing thermal stresses occur, affecting the performance of sandwich panels used in the structure. This may result in the corrugation of the external surface or – in the worst case – the panel fixed to an intermediate support may be damaged. The EN 14509 standard, describing the requirements for sandwich panels, introduced a division into three groups of colours: very light, light and dark. The value of temperature of the facing is specified according to the colour group as follows: +55°C for very light colours, +65°C for light colours and +80°C for dark colours. The ambient temperature inside the building used for calculations was 20°C. In summer, the facing temperatures used were the maximum allowable temperatures specified for each colour group, whereas in winter the

assumed temperature was -20° C. Therefore, the calculations considered the following temperature gradients for each colour group:

- Group I –  $\Delta t = 40^{\circ}\text{C}$ ,
- Group II –  $\Delta t = 45^{\circ}\text{C}$ ,
- Group III –  $\Delta t = 60^{\circ}\text{C}$ ,

This complies with the requirements specified for sandwich panels in EN 14509 for our latitude.

**16. Guidelines for the application of dark colour sandwich panels**

External wall cladding made of dark-coloured panels (Group III), due to exposition to substantially greater thermal stresses than in the case of lighter colours may become deformed or lose the initial shape. It is the designer’s responsibility to take this fact into account in the design process and – in order to prevent damage – apply a solution that will meet all three requirements specified below:

1. Select fixing method and static scheme according to TrayPan,
2. Reduce the maximum length of panels
3. Consider the temperature at which panels will be installed.

**1. Static scheme and fixing method**

Both in the case of wall and roof panels the installation system must be verified in TrayPan software, i.e. the contemplated static scheme must meet the ULS and SLS criteria. TrayPan allows to create any static scheme with appropriate loads [dead load, live load, thermal load, wind load, snow load (for roof panels)]. TrayPan enables also the selection of panels depending on various parameters: U parameter, fire resistance, acoustic parameters.

Colour group	Colours
Group I – very light colours	RAL: 1015, 1016, 1018, 6019, 9001, 9002, 9010, RR: 20, 106
Group II – light colours	RAL: 1002, 1003, 1004, 1014, 1017, 1019, 1021, 1023, 1035, 2000, 2003, 2004, 2008, 2009, 5012, 5018, 5024, 6021, 6033, 7000, 7035, 7037, 7040, 9006, 9022, RR: 21, 24, 30, 40
Group III – dark colours	RAL: 3000, 3002, 3003, 3005, 3009, 3011, 3013, 5002, 5003, 5005, 5009, 5010, 5011, 5022, 6000, 6003, 6005, 6011, 6018, 6020, 6029, 7015, 7016, 7022, 7024, 8016, 8017, 8023, 9005, 9007, RR: 22, 23, 29, 34, 35, 36, 41, 288

However, regardless of the selection of panel types according to TrayPan, it is recommended to install dark-coloured wall sandwich panels only in single-span systems.

Using dark panels in multi-span layouts may result in the occurrence of slight corrugation on the intermediate support due to greater thermal stresses. Although formally allowed by the product standard, the corrugation may cause the client or project owner to express reservations on aesthetic grounds and lead to a quality claim.

Ruukki does not guarantee homogeneous flatness of the surface of dark sandwich panels installed using multi-span systems, unless such applications have been approved in writing by Ruukki's representative..

### 2. Maximum panel length

The maximum installation length of Colour Group III wall panels is 9.5 m.

The maximum installation length of Colour Group III roof panels is 13.5 m.

Dark-coloured panels with lengths exceeding the limit values shown above are not covered by the Ruukki guarantee, unless the relevant application has not been approved in writing by representative of Ruukki.

### 3. Installation temperature

The installation of sandwich panels with dark-colour facing at low temperatures increases the effects of thermal load on the structure in warm seasons. Therefore, it is recommended to install such panels at ambient temperatures above 10°C.

Dark-coloured panels installed at temperatures below 10°C are not covered by the Ruukki guarantee, unless the relevant application has been approved in writing by representative of Ruukki.

## 17. Guidelines for the application of flat surface panels

Sandwich panels with flat (smooth) facing should be installed using single-span system only. The possibility of application of panels with flat facing must be verified using TrayPan software.

The application of flat surface panels in other installation systems may result in undesirable visual effects, e.g. corrugation. The effects may be of a temporary nature, i.e. they may occur in specific conditions (e.g. after a prolonged exposure to the sun) and although they do not affect the performance of the panel, the client or project owner may complain about the disturbed aesthetics of the façade.

The guarantee obligations of Ruukki do not apply to flat surface panels installed using multi-span systems, unless the relevant application has been approved in writing by Ruukki's representative.

Ruukki shall not be held responsible for panel damages arising as a result of designer non-compliance with the guidelines.

## IV. Maintenance

### 1. Preliminary information

It is recommended to take into account (at the designing stage) the technical solutions limiting the risk of corrosion. In particular, it is necessary to ensure proper roof drainage and watertight and capable sewage system, to limit junctions creating thermal bridges and to prevent the occurrence of moisture on the facings. It is important to take into account recommendations concerning transport, unloading, storage and installation of Ruukki sandwich panels during erection of the building. It is necessary to consider proper protections in order to prevent mechanical damages to panels (e.g. bumper block, plinth). In case of occurrence of minor damage to organic coating during installation or operation of the building it is necessary to repair it immediately. Damage to the coating causes that environment pollution affects zinc layer resulting in its degradation by soluble salts. In addition, many impurities absorb water causing the corrosion. The renovation painting should be done if significant area of the facing is damaged. Replacement of the panel should be considered if the facing (metal sheet) is damaged.

Guidelines for the use of sandwich panels with stainless steel facings may be found at [ruukki.com](http://ruukki.com).

### 2. Removal of snow and dirt.

Care should be taken when removing snow from the roof in order not to damage the facing of sandwich panel. Leaves and rubbish remaining on the roof should be removed every year or even more often if it is necessary. Hollows and roof drainage systems should be cleaned at least once per year. It is forbidden to leave (e.g. after installation of roof panels) an assembly tools, pieces of the sheet, swarf or other metal elements which constitute the risk of corrosion and danger to the human health and safety – e.g. in case of fall from a height.

### 3. Inspection

It is recommended to inspect the surface of sandwich panels and flashings at least once per year (especially eaves, joints between panels and flashings, panel edges etc.). Bear in mind that the higher is corrosion aggressiveness of the environment, the more frequent and detailed inspection should be. It is also recommended to inspect fastenings of panels and flashing at least once per year. Lack of fasteners (or their damage) may cause leakage or moisture which lead to the corrosion. All damaged fasteners must be replaced and those that are loose must be tighten.

### 4. Sealings

It is necessary to apply additional sealing in addition to those which are used in standard (sealing compounds, seals) in the joints between the panels in case of objects whose operation requires to wash the facings frequently.

It is required in order to prevent penetration of the moisture and deterioration of panel parameters. Therefore it is recommended to use butyl/polyurethane sealant (with neutral pH). It is not allowed to use sealants with acid pH. All sealants have to be inspected regularly and replaced if necessary.

### 5. Washing of the facing surface

Washing of the facing surfaces should be done in order to remove the dirt which deteriorates the aesthetics and affects anti-corrosion coating. In case of food industry buildings which are required to ensure microbiological purity special cleaning and disinfecting products are used. Therefore there are several factors which determine whether the cleaning/disinfecting product can be used:

- Type of the facing and organic coating.
- Cleaning frequency.
- Cleaning precision.

Some detergents may be added if it is difficult to remove the dirt with water alone. It is recommended to use well soluble detergents of pH 4-9. After each washing, it is necessary to remove detergent by rinsing the facing surface with fresh water. Where special industrial cleaning/disinfecting chemicals have to be used, manufacturer instructions have to be followed. Before applying detergent to whole element, it is recommended to check (on the small area) if it does not damage the organic coating of the sheet. Concentration of detergent should be in accordance with manufacturer's instructions. The temperature of cleaning agent should not be higher than 30°C and it should not act on the facing surface more than 30 minutes.

Pressure of the water used for rinsing should not exceed 5 MPa (50 bar) at the outlet of the nozzle and 0.04 MPa when hitting the facing surface (such pressure at the point of impact is caused by the stream of 5 MPa pressure coming out of the nozzle inclined at 30° in the distance of 20-30 cm from the panel). It is necessary to rinse the facing surface carefully, starting from the top of the panel in order to remove detergent completely. At the end, the drainage system has to be rinsed (sewage system, gutters etc.). Generally the temperature of water should not exceed 30°C. Removal of grease is an exception – in this case water temperature may be increased temporarily up to 50°C. Grease may be removed with soft cloth and white spirit. After cleaning such surfaces it is necessary to rinse them with water alone. It is forbidden to use organic solvents and abrasive cleaners. In the rooms where temperature is below 0°C neither steam cleaning nor rinsing can be performed.

After completion of assembly and removing the protective film, manually remove all dirt, grease and dust, with (pH~7) water solution of mild cleaning agent, using cotton cloth or sponge. Next, rinse the surface with fresh water. Cleaning should be done in temperatures above zero.

## 6. Painting

Visual inspection of organic coating is required before commencement of any painting works (corrective painting/repainting).

### Painting of the panel edges

After the cutting, panel edges should be cleaned, degreased and protected with varnish layer on the width of 5 mm. Where the edges of the panels were precut at the factory no additional protective works need to be done.

### Corrective painting (surface damage)

Damaged area has to be cleaned and degreased before commencement of painting works. After drying of the damaged area corrective painting should be carried out using the smallest available paintbrush. It is enough to paint damaged area once if the damage affected only the top layer of the facing. If the zinc layer was damaged also, it is recommended to apply second paint layer when the previous one is dry (surface has to be protected from the dust during painting works). It is recommended to use ESSVE roofing paint to repair facings with organic coating (renovation paint for the steel with coil-coating system).

### Renovation painting or colour change

Durability of organic coating depends on many factors which causes that it is difficult to determine particular time when renovation should be done. However, the basic reasons for repainting are: damages (imperfections) to the surface and significant changes of colour and gloss. Renovation method depends on the surface condition. There may occur different imperfections to the facing surface such as: cracking, peeling, blisters, lack of interlayer adhesion, areas with corroded zinc (white zinc salts) or visible steel corrosion. All imperfections have to be removed before commencement of painting works (e.g. mechanically by scraping, sanding). It is necessary to remove imperfections carefully not to damage steel facing. In the areas where steel corrosion occurs, it is necessary to remove it with brush or sandpaper and to remove the dust. It is required to degrease the surface before commencement of painting works.

## V. Final remarks

Information about flashings, fasteners and other elements used for assembly works is provided in the catalogue 'Accessories for nSPB, SP2B, SP2D, SP2C, SPC sandwich panels'. For the cases which are not provided in the catalogue, assembly works have to be done according to the details of lightweight housing design. According to Ruukki experience, the most common reasons for performance defects reported for structures made in Ruukki light housing design, are the following:

- Applying solutions other than recommended by the sandwich panel manufacturer.

- Replacing the manufacturer-recommended materials with others.
- Not knowing recommended solutions.
- Failure to utilize professional equipment.
- Untrained workers fixing the panels.

Any possible complaints may be rejected and the warranty may be lost if the assembly works were not done according to recommendations given in assembly instruction.

Due to high defect removal cost we encourage you to make use of the information available in our catalogues or to visit us at [www.ruukki.com](http://www.ruukki.com). Also consultancy services rendered by our employees are available.

**VI. Flashings assembly guidelines**

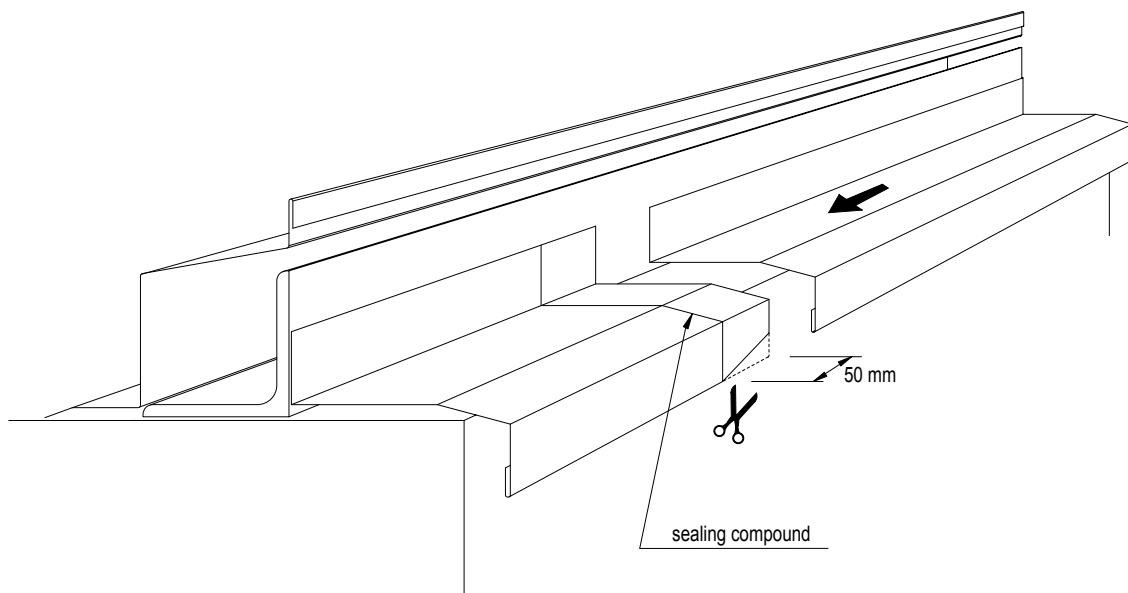

Fig. 16. Joining the plinth flashing.

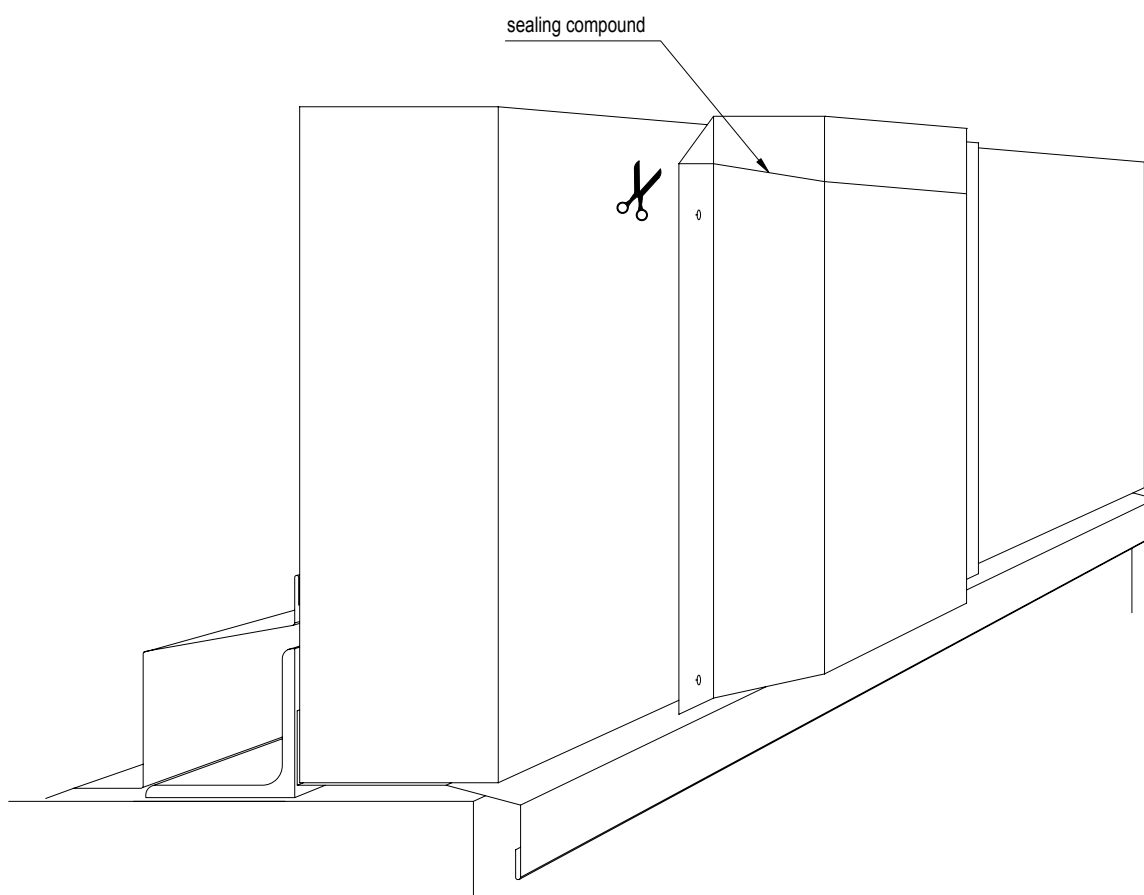

Fig. 17. Joint between the plinth and vertical flashing.

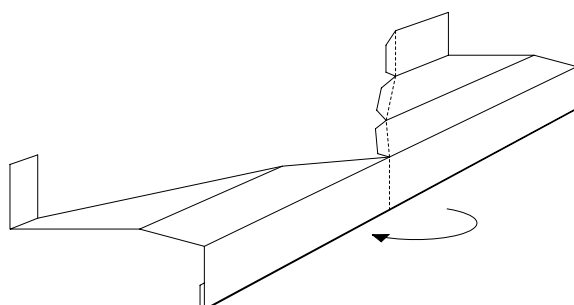
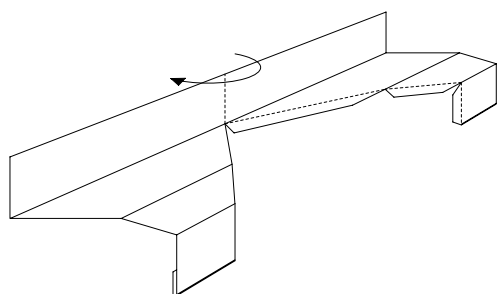
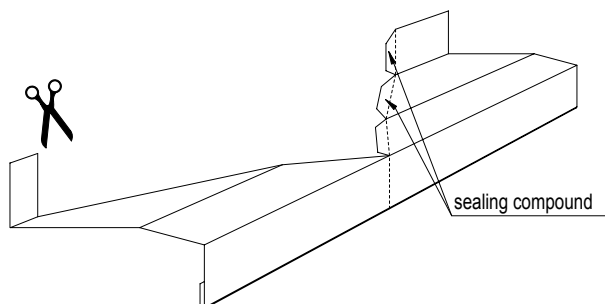
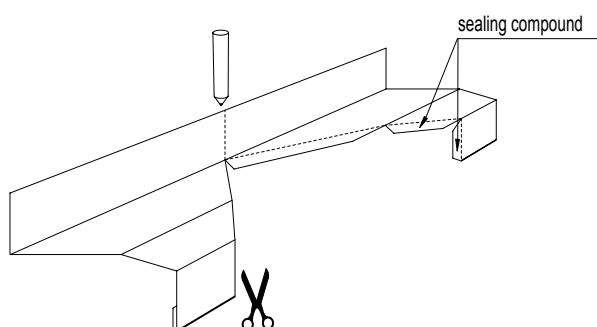
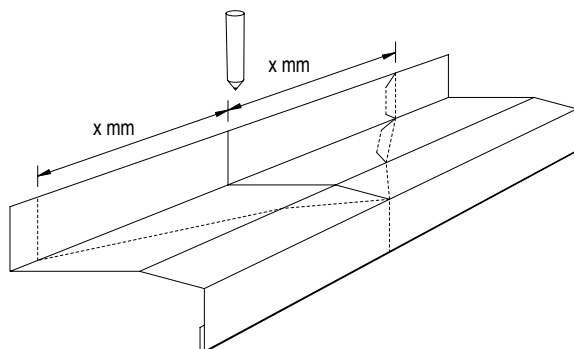
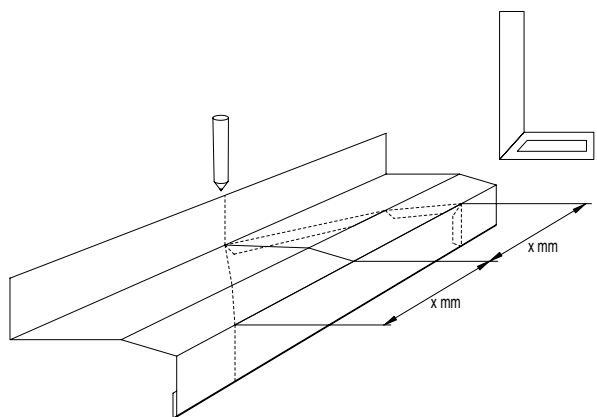

Fig. 18. External plinth corner.

Fig.19. Plinth flashing external corner.

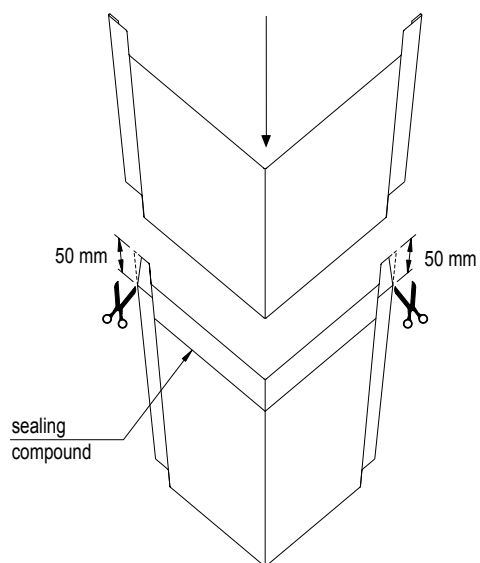

Fig. 20. Joining the corner flashing.

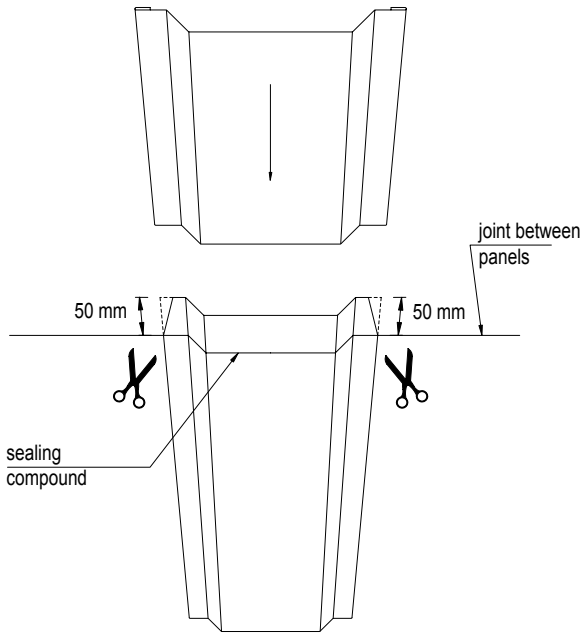

Fig. 21. Joining the vertical flashing.

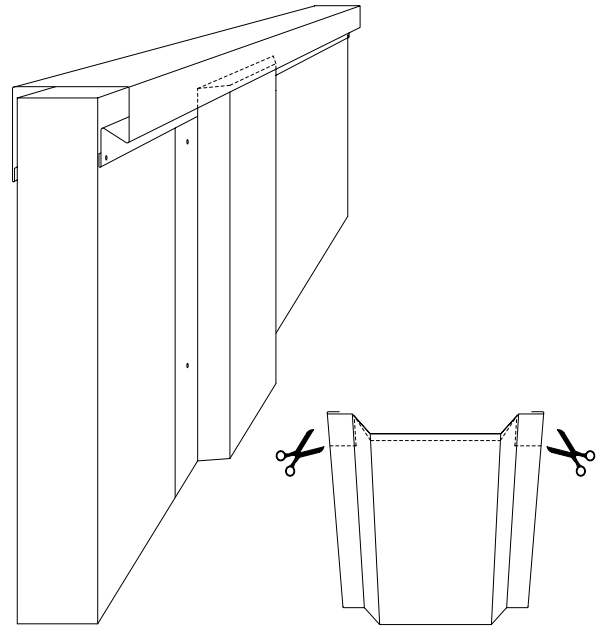

Fig. 21. Joint between the roof flashing and vertical flashing.

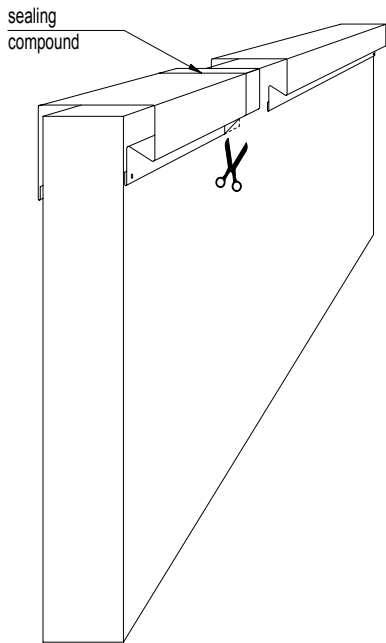

Fig. 23. Joining the cornice strip.

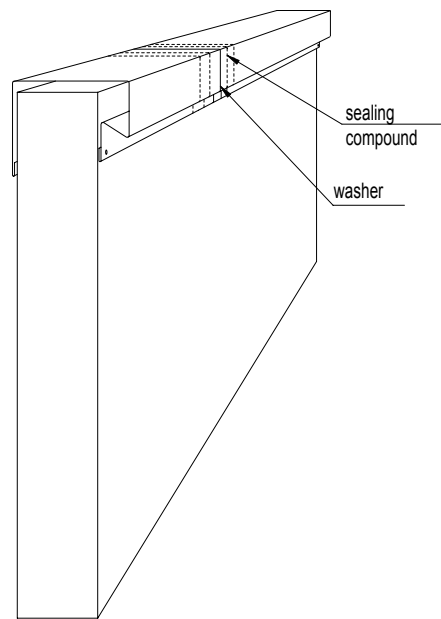
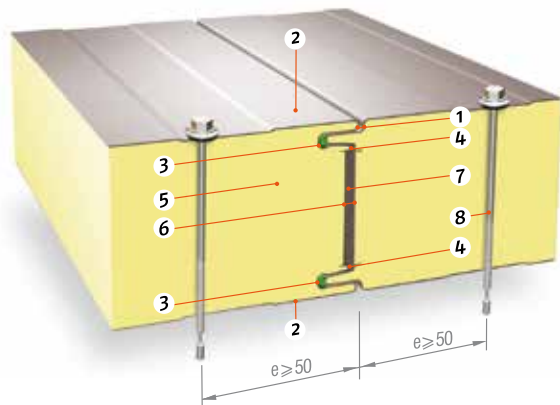

Fig. 24. Joining the cornice strip with additional plate sheet.

## VII. Joints between the panels

- Joint between Ruukki SP2B panels with PIR core



1. Proper bending radius allows to keep coating properties.
2. Profiling of facings ensures a unified and harmonious look.
3. Energy seal in case of Ruukki Energy Panels or EPDM seal applied on customer's request increase air tightness.
4. Designed shape of profiled edges ensures air-tightness and increased thermal insulation
5. Rigid, HCFC-free, self-extinguishing and sustainable polyisocyanurate foam (PIR) with excellent thermal insulation properties.
6. Aluminium foil prevents from gases diffusion and water vapour ingress.
7. Polyurethane gasket ensures air-tightness and right thermal insulation.
8. Panel screw

- Joint between Ruukki nSPB panels with mineral wool core

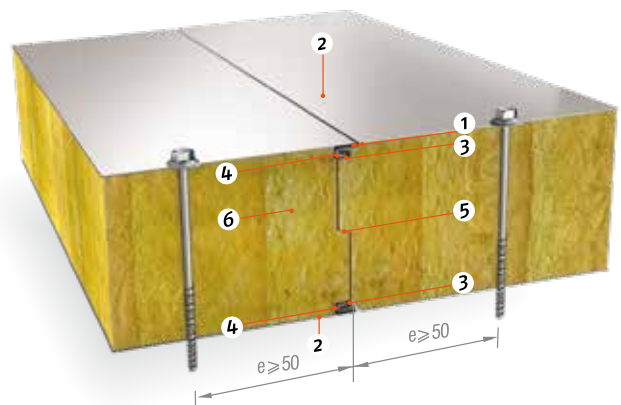

1. Proper bending radius allows to keep coating properties.
2. Profiling of facings ensures a unified and harmonious look.
3. Double joint from internal and external size is designed for easy installation and proper performance in case of fire.
4. Butyl sealing (applied on site) or EPDM seal applied on customer's request increase air tightness. In case of Ruukki Energy Panels - Energy seal is applied in the factory.
5. Properly milled core increases air-tightness and fire resistance values.
6. Core made of non-combustible and environmentally friendly mineral wool ensures very good fire resistance values.
7. Panel screw

• Joint between Ruukki SP2D panels with PIR core

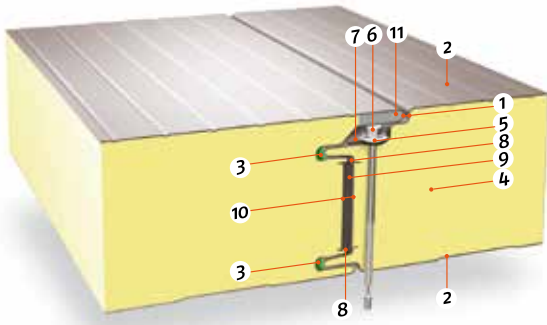

1. Proper bending radius allows to keep coating properties.
2. Profiling of facings ensures a unified and harmonious look.
3. Energy seal in case of Ruukki Energy Panels or EPDM seal applied on customer's request increase air tightness.
4. Rigid, HCFC-free, self-extinguishing and sustainable polyisocyanurate foam (PIR) with excellent thermal insulation properties.
5. Groove enables precise installation.
6. Panel screw
7. Panel fixing L16 or L16 C/N
8. Designed shape of profiled edges ensures air-tightness and increased thermal insulation
9. Polyurethane gasket ensures air-tightness and right thermal insulation.
10. Aluminium foil prevents from gases diffusion and water vapour ingress
11. Polyurethane gasket enables gases to diffuse.

• Joint between Ruukki nSPD panels with mineral wool core

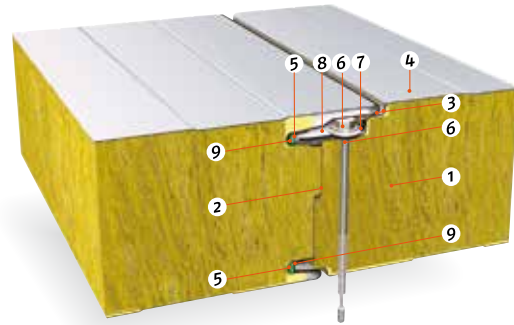

1. Core made of non-combustible and environmentally friendly mineral wool ensures very good fire resistance values.
2. Properly milled core increases air-tightness and fire resistance values.
3. Proper bending radius allows to keep coating properties.
4. Profiling of facings ensures a unified and harmonious look.
5. Double joint from internal and external side is designed for easy installation and proper performance in case of fire.
6. Groove enables precise installation.
7. Panel screw
8. Panel fixing L15
9. Butyl sealing (applied on site) or EPDM seal applied on customer's request increase air tightness. In case of Ruukki Energy Panels - Energy seal is applied in the factory.

• Joint between Ruukki SP2E panels with PIR core

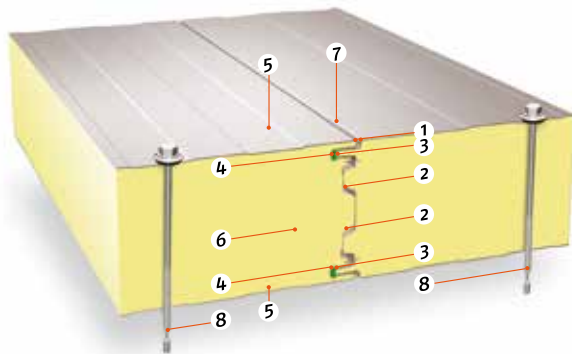

1. Proper bending radius allows to keep coating properties.
2. Properly milled core eliminates thermal bridge.
3. Double joint from internal and external side is designed for easy installation and proper performance in case of fire.
4. Butyl sealing (applied on site) or EPDM seal applied on customer's request increase air tightness. In case of Ruukki Energy Panels - Energy seal is applied in the factory
5. Profiling of facings ensures a unified and harmonious look.
6. Rigid, HCFC-free, self-extinguishing and sustainable polyisocyanurate foam (PIR) with excellent thermal insulation properties.
7. Permanently elastic sealing compound (obligatory for ceilings/optional for walls) is to be applied on site.
8. Panel screw

• Joint between Ruukki SP2C panels with PIR core

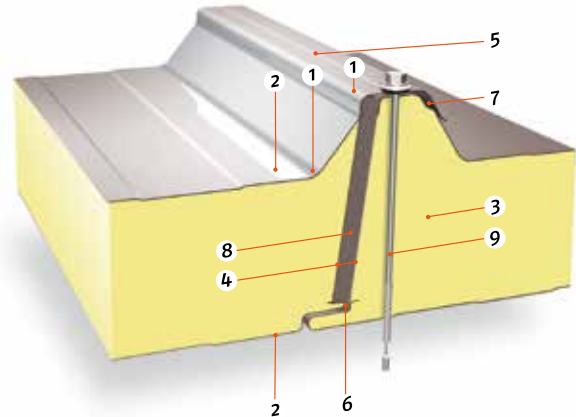

1. Proper bending radius allows to keep coating properties.
2. Profiling of facings ensures a unified and harmonious look.
3. Rigid, HCFC-free, self-extinguishing and sustainable polyisocyanurate foam (PIR) with excellent thermal insulation properties.
4. Aluminium foil prevents from gases diffusion and water vapour ingress
5. Groove enables precise installation.
6. Designed shape of profiled edges ensures air-tightness and increased thermal insulation
7. Micro-chamber prevents from capillary rise of water.
8. Polyurethane gasket ensures air-tightness and right thermal insulation.
9. Panel screw

• **Joint between Ruukki nSPC panels with mineral wool core**

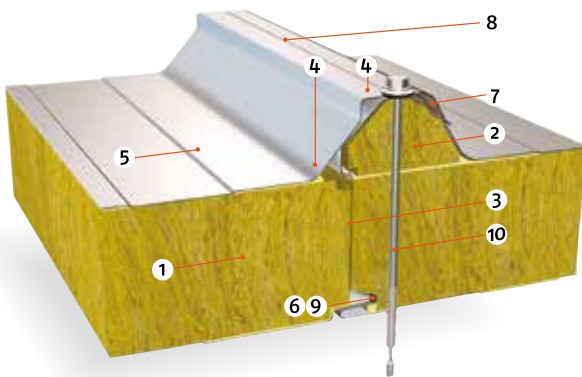

1. Core made of non-combustible and environmentally friendly mineral wool ensures very good fire resistance values.
2. Rib is filled with non-combustible and environmentally friendly mineral wool.
3. Properly milled core increases air-tightness and fire resistance values.
4. Proper bending radius allows to keep coating properties.
5. Profiling of facings ensures a unified and harmonious look.
6. Joint from internal side is designed for easy installation and proper performance in case of fire.
7. Micro-chamber prevents from capillary rise of water.
8. Groove enables precise installation.
9. Factory-applied EPDM seal.
10. Panel screw.



Engineering and construction company Rauta is the leading supplier of reliable building solutions in Ukraine and European Union.

Rauta provides complete solutions including: building design, supply of frames, sandwich panels, facades, prefabricated buildings, fireproofing, as well as installation and related services.

The company uses only certified European produced materials. Rauta is the exclusive supplier to Ukraine of Ruukki commercial products and the developer of innovations that reduce the cost and term of construction.

Everything we construct is building our reputation!

**RAUTA**  
RELIABLE SOLUTIONS

Starokyivska str. 10G,  
Kyiv, Ukraine, 04116, BC Vector  
+38 044 364-85-73  
info@rautagroup.com  
[www.rautagroup.com](http://www.rautagroup.com)